

4.0kW Inverter Petrol Generator

IMPORTANT! PLEASE READ THESE INSTRUCTIONS CAREFULLY. NOTE ALL SAFETY INSTRUCTIONS AND WARNINGS. USE THE PRODUCT CORRECTLY AND WITH CARE FOR THE PURPOSE FOR WHICH IT IS INTENDED. FAILURE TO FOLLOW THESE INSTRUCTIONS MAY CAUSE DAMAGE TO PROPERTY AND/OR PERSONAL INJURY.

PLEASE KEEP THESE INSTRUCTIONS SAFE AND AVAILABLE FOR FUTURE REFERENCE.

CERTIFICATE OF GUARANTEE

This product is guaranteed for a period of 2 Years, with effect from the date of purchase and applies only to the original purchaser. This guarantee only applies to defects arising from, defective materials and or faulty workmanship that become evident during the guarantee period only and does not include consumable items. The manufacturer will repair or replace the product at their discretion subject to the following. That the product has been used in accordance with the guidelines as detailed in the product manual and that it has not been subjected to misuse, abuse or used for a purpose for which it was not intended. That it has not been taken apart or tampered with in any way whatsoever or has been serviced by unauthorised persons or has been used for hire purposes. Transit damage is excluded from this guarantee, for such damage the transport company is responsible. Claims made under this guarantee must be made in the first instance, directly to the retailer within the guarantee period. Only under exceptional circumstances should the product be returned to the manufacturer. In this case it shall be the consumer's responsibility to return the product at their cost ensuring that the product is adequately packed to prevent transit damage and must be accompanied with a brief description of the fault and a copy of the receipt or other proof of purchase. The manufacturer shall not be liable for any special, exemplary, direct, indirect, incidental, or consequential loss or damage under this guarantee. This guarantee is in addition to and does not affect any rights, which the consumer may have by virtue of the Sale of Goods Act 1973 as amended 1975 and 1999.

INTRODUCTION

Thank you for purchasing this product which has passed through our extensive quality assurance process. Every care has been taken to ensure that it reaches you in perfect condition. However, in the unlikely event that you should experience a problem, or if we can offer any assistance or advice please do not hesitate to contact our customer care department. For details of your nearest customer care department please refer to the telephone numbers at the back of this manual.

Safety First

Before attempting to operate this product the following basic safety precautions should always be taken to reduce the risk of fire, electric shock and personal injury. It is important to read the instruction manual to understand the application, limitations and potential hazards associated with this product.

HELPLINE & SPARE PARTS

In the unlikely event of a defect occurring please contact our Helpline.
Office hours: Monday - Friday 9:00am - 5:00pm. Telephone Number 01332 576 850

INTENDED USE

This generator is designed and intended only for supplying electrical power for operating compatible electrical lighting, appliances, tools and motor loads.

IMPORTANT SAFETY INSTRUCTIONS

The purpose of safety rules is to attract your attention to possible dangers. The safety symbols and the explanations with them, require your careful attention and understanding. The safety warnings do not by themselves eliminate any danger. The instruction or warnings they give are not substitutes for proper accident prevention measures.

SAFETY ALERT SYMBOL



Indicates danger, warning, caution or notice. May be used in conjunction with other symbols or pictures.

DANGER indicates a hazardous situation which, if not avoided, will result in death or serious injury.

WARNING indicates a hazardous situation which, if not avoided, could result in death or serious injury.

CAUTION indicates a hazardous situation which, if not avoided, could result in minor or moderate injury.

NOTICE indicates information considered important, but not hazard-related (e.g., messages relating to property damage).

Failure to obey a safety warning can result in serious injury to yourself or to others. Always follow the safety precautions to reduce the risk of fire, electric shock and personal injury.

Do not attempt to operate this tool until you have read thoroughly and completely understood the safety rules, etc. contained in this manual. Failure to comply can result in accidents involving fire, electric shock or serious personal injury. Save this Owners Operating Manual and review it frequently for continual safe operation and for instructing others who may use this tool.



Do not use E15 or E85 fuel in this product. It will damage the unit and void your warranty. Only use unleaded gasoline containing up to 10% ethanol.

Due to continued product refinement policy, product features and specifications can and will change without notice. Check current features and specifications with your retailer.



DANGER: CARBON MONOXIDE

Using a generator indoors CAN KILL YOU IN MINUTES.

Generator exhaust contains carbon monoxide, a colourless, odourless, poisonous gas. Breathing carbon monoxide will cause nausea, dizziness, fainting or death. If you start to feel dizzy or weak, get to fresh air immediately.

OPERATE GENERATOR OUTDOORS ONLY IN A WELL VENTILATED AREA AND POINT EXHAUST AWAY.

DO NOT operate the generator inside any building, including garages, basements, crawlspaces and sheds, enclosure or compartment, including the generator compartment of a recreational vehicle.

DO NOT allow exhaust fumes to enter a confined area through windows, doors, vents or other openings.



DANGER: Using a generator indoors CAN KILL YOU IN MINUTES.

NEVER use inside a home or garage, **EVEN IF** doors and windows are open.

ONLY use **OUTSIDE** and far away from windows, doors, and vents.

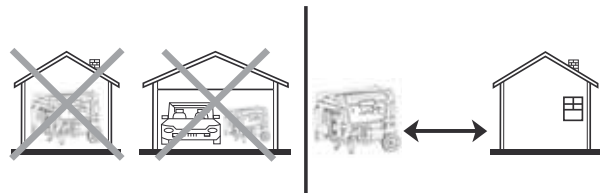

Install battery-operated carbon monoxide alarms or plug-in carbon monoxide alarms with battery back-up according to the manufacturer's instructions.

IMPORTANT SAFETY INSTRUCTIONS



WARNING: Read and understand all instructions. Failure to follow all instructions listed below could result in electrocution, fire, and/or carbon monoxide poisoning, which can cause death or serious injury.



WARNING: In some applications, National Electric Code requires the generator to be grounded to an approved earth ground. Before using the ground terminal, consult a qualified electrician, electrical inspector, or local agency having jurisdiction for local codes or ordinances that apply to the intended use of the generator.

SAVE THESE INSTRUCTIONS

The generator must be mounted on a firm level surface.

DO NOT allow children or untrained individuals to use this unit.

Keep all bystanders, children, and pets at least 10 feet away.

Wear sturdy and dry shoes or boots. Do not operate while barefoot.

DO NOT operate generator when you are tired or under the influence of drugs, alcohol, or medication.

The electrical output load must not exceed the maximum load stated on the rating plate.

Exceeding the rated load will damage the unit or shorten its life and will invalidate the guarantee.

The engine must not be run at speeds that exceed the maximum stated on the rating plate.

Operating an engine at excessive speeds increases the hazard of personal injury.

DO NOT tamper with components, which may increase or decrease the governed speed.

Mains extension leads, mains supply leads, and all electrical equipment must be in good working condition.

Never operate electrical equipment with damaged or defective mains supply leads.

Keep the area around the generator clear of obstructions at all times. Never locate the generator against a building or near a canvas or plastic structure i.e. Tents etc.

Always use the correct fuel mix as stated in the user manual and on the rating plate.

To reduce the risk of fire and burn injury, handle fuel with care. It is highly flammable.

DO NOT smoke while handling fuel.

Store fuel in a container approved for gasoline.

To prevent fire, always stop the engine and allow to cool for five minutes before refuelling and never over fill the fuel tank.

Loosen fuel cap slowly to release pressure and to keep fuel from escaping around the cap.

Tighten the fuel cap securely after refuelling.

Wipe spilled fuel from the unit.

Never attempt to burn off spilled fuel under any circumstances.

Always clean up spilt fuel immediately using sand.

DO NOT use the generator in or near an explosive atmosphere.

To prevent an electric shock, never operate the machine in rain, snow or touch with wet hands.

Check the fuel system periodically for leaks. Seals and hoses should be checked for signs of deterioration or chafing. Check for loose or missing clamps damaged fuel tank or filler cap. All defects should be corrected before further use.

Always allow the generator to reach full operating speed before connecting any electrical load. Always disconnect the electrical load before switching the generator off.

IMPORTANT SAFETY INSTRUCTIONS

To prevent surging that may possibly damage electrical equipment, do not allow engine to run out of fuel while electrical loads are connected.

Before transporting the generator in a vehicle, drain all fuel to prevent spillage.

To prevent an electric shock and fire, never connect an electrical load with the electrical output switched on.

DO NOT connect the generator to any other electrical source.

Before storing, allow the engine to cool for 30 minutes and drain fuel from the unit.

DO NOT store the generator in rain, snow, or wet weather.

Store the generator in a well-ventilated area with the fuel tank empty. Fuel should not be stored near the generator.

Empty fuel tank, place the engine switch / fuel valve / choke lever in the OFF position, and restrain the unit from moving before transporting in a vehicle.

Provide a plastic sheet or absorbent pad below the generator to catch any drips of fuel or lubricant when transporting.

Generators vibrate in normal use. During and after the use of the generator, inspect the generator as well as extension cords and power supply cords connected to it for damage resulting from vibration. Have damaged items repaired or replaced as necessary. Do not use plugs or cords that show signs of damage such as broken or cracked insulation or damaged blades.

Use a ground fault circuit interrupter (GFCI) in damp areas and areas containing conductive material such as metal decking.

Connection to your home's electrical system requires a listed 30A automatic transfer switch installed by a licensed electrician and approved by the local authority having jurisdiction. The connection must isolate the generator from the utility power and must comply with all applicable laws and electrical codes.

For power outages, permanently installed stationary generators are better suited for providing back-up power to the home. Even a properly connected portable generator can become overloaded. This may result in overheating or stressing the generator components, possibly leading to generator failure.

Inspect the unit before each use for loose fasteners, fuel leaks, etc. Replace damaged parts.

Use only recommended or equivalent replacement parts and accessories. Use of any other parts or failure to follow maintenance instructions may create a risk of shock or injury.



WARNING: Do not use generator for medical and life support uses.

NEVER use this product to power life support devices or life support appliances.

NEVER use this product to power medical devices or medical appliances.

Inform your electricity provider immediately if you or anyone in your household depends on electrical equipment to live.

Inform your electrical provider immediately if a loss of power would cause you or anyone in your household to experience a medical emergency.

FUEL FILLING SAFETY RULES



DANGER: RISK OF FIRE AND SERIOUS BURNS. Never remove fuel cap when unit is running. Shut off engine and allow the unit to cool at least five minutes. Remove cap slowly.



WARNING: Select bare ground for fuelling and move at least 10 feet (3m) from fuelling spot before starting the engine. After refuelling, properly tighten fuel cap; wipe off any spilled fuel and check for leakage.

IMPORTANT SAFETY INSTRUCTIONS



WARNING: If fuel gets spilled on clothes, especially trousers, it is very important to change clothes immediately. Do not rely on evaporation. Flammable quantities of fuel may remain on clothes after a spill for longer than expected.



WARNING: Vibrations can cause an improperly tightened fuel cap to loosen or come off and spill quantities of fuel. In order to reduce the risk of fuel spillage and fire, tighten fuel filler cap by hand as securely as possible. Before use always make sure that the fuel cap has been properly tightened. Check for fuel leakage while refuelling and during operation. If a fuel leak is suspected, do not start or run the engine until leak is fixed and spilled fuel has been wiped away.

ADDING FUEL

Turn the generator off and let it cool for at least five minutes before removing the fuel cap. Loosen the cap slowly to relieve pressure in the tank.

Only fill or drain fuel outdoors in a well-ventilated area.

DO NOT pump gasoline directly into the generator at the gasoline station. Use an approved container to transfer the fuel to the generator.

DO NOT overfill the fuel tank.

Always keep fuel away from sparks, open flames, pilot lights, heat and other sources of ignition.

DO NOT light or smoke cigarettes.

WHEN STARTING THE GENERATOR

DO NOT attempt to start a damaged generator.

Make certain that the gas cap, air filter, spark plug, fuel lines and exhaust system are properly in place.

Allow spilled fuel to evaporate fully before attempting to start the engine.

Make certain that the generator is resting firmly on level ground.

SPECIFIC SAFETY RULES



WARNING: Do not use the generator in areas where there is a risk of explosion or fire from combustible materials. The sparks possibly caused when using this generator may ignite combustible materials as well as flammable liquids, paint, varnish, petrol, flammable gases and dust of an explosive nature. As a precaution it is recommended that you consult an expert on a suitable fire extinguisher and its use. Ensure that the work area is kept clear of combustible materials.



WARNING: Do not use the generator indoors or in confined spaces where exhaust gases, smoke or fumes could reach dangerous concentrations.

Exhaust fumes contains poisonous carbon monoxide, a colourless, odourless gas. Breathing exhaust fumes can cause loss of consciousness and can lead to death. If running in a confined or partially enclosed area, the air may contain a dangerous amount of carbon monoxide.

To keep exhaust fumes from building up, always provide adequate ventilation.

Always use a battery-powered carbon monoxide detector when running the generator. If you begin to feel sick, dizzy, or weak while using the generator, shut it off and get to fresh air immediately. See a doctor. You may have carbon monoxide poisoning.

Place the generator on a flat, stable surface with a slope of no more than 4°.

Operate in a well-ventilated, well-lit area isolated from working areas to avoid noise interference.

Operating the generator in wet conditions could result in electrocution. Keep the unit dry.

DO NOT touch bare wires or receptacles.

NEVER connect this generator to a second generator.

IMPORTANT SAFETY INSTRUCTIONS

Rapid retraction of the recoil cord will pull hand and arm towards the engine faster than you can let go. Broken bones, fractures, bruises or sprains could result. Unintentional startup can result in entanglement, traumatic amputation or laceration.

When starting engine, pull the recoil cord slowly until resistance is felt and then pull rapidly to avoid kickback.

Unit will become hot during use. Please keep generator at least one metre (1m) away from buildings, other equipment, pedestrian areas or flammable materials.

DO NOT touch the muffler or cylinder during or immediately after use; they are HOT and will cause burn injury.

DO NOT operate the generator near hazardous material.

NEVER pull the recoil starter once the generator engine has started. Any damage caused will not be covered by warranty.

NEVER start or stop the generator with any appliances attached.

Ensure the generator has stopped before servicing, or lubricating etc.

DO NOT attempt to modify the generator, guards or the supplied accessories in any way.

DO NOT touch the exhaust. This can become very hot during operation and can cause serious burns.

Always check the generator for damaged parts or fuel leaks, ensure these are fixed before using it.

NEVER refuel while smoking or in the vicinity of an open flame.

Always wear safety eye wear, ear and breathing protection when operating or refuelling the generator.

To avoid a fire if you spill fuel while refuelling, clean up before starting the generator.

NEVER operate or store the generator on its side,

ALWAYS operate or store in an upright manner on firm, solid ground.

Your generator is factory set, **NEVER** attempt to speed it up as this could endanger the user and damage the generator and/or attached appliances.

NEVER operate the generator in damp, wet or flooded conditions.

Before plugging appliances into the generator allow it to run up to full speed.

If the generator makes an unfamiliar sound or vibrates excessively, switch the generator 'OFF' immediately.

Investigate the possible cause or consult your authorised service agent.

DO NOT use ANY type of coolant on the generator as a fatal electric shock could occur.

NEVER use coolant in the generator as damage may occur.

DO NOT touch the generator with wet hands as this may cause electrocution.

NEVER use your generator on highly conductive surfaces. e.g. Steel walk ways, metal roof or metal bench, as this could cause an electric shock.

Always operate your generator at least two (2) metres away from conductive surfaces.

Locate this generator in a convenient place, avoid using long extension leads.

If an extension lead is used, avoid leaving it where it may be damaged by pedestrian or vehicular traffic or cause a trip and fall hazard.

When using extension lines or mobile distribution networks the total length of lines for a cross section of 1.5mm² should not exceed 60m; for a cross section of 2.5mm² this should not exceed 100m.

The unit operates best in temperatures between 5°C and 40°C with a relative humidity of 30~95%.

IMPORTANT SAFETY INSTRUCTIONS

Always observe normal safety precautions with ALL appliances used with this generator.

NEVER transport the generator with fuel in the tank. **ALWAYS** empty the fuel tank.

All loads must be kept within the ratings stated on the rating plate. Overloading the generator will damage the unit or shorten its life. This will not be covered under warranty.

DO NOT tamper or alter any parts as this may cause personal injury or damage the generator.

Always disconnect any loads before starting or stopping the generator.

When storing the generator always store in a secure well ventilated area.

Always store in an upright position. **NEVER** store or lay this generator on its side.

Keep children a minimum of 3m away from the generator at all times.

Save these instructions. Refer to them frequently and use them to instruct others who may use this tool. If you loan someone this tool, loan them these instructions also.

Sparks can result in fire or electrical shock.

Rotating parts can entangle hands, feet, hair, clothing and/or accessories. Keep hands and feet away from rotating parts. Tie up long hair and remove jewellery. Operate equipment with guards in place. **DO NOT** wear loose-fitting clothing, dangling drawstrings or items that could become caught.

When servicing the generator: Disconnect the spark plug wire and place it where it cannot contact the plug. **DO NOT** check for spark with the plug removed. Use only approved spark plug testers.

For outdoor use only.

CHECK DAMAGED PARTS

Before using the generator it should be carefully checked to determine that it will operate properly and perform its intended function.

Check for broken or missing parts and have them replaced or repaired at an authorised service facility. Check any other condition that may affect the operation of the generator. A guard or any other part of the generator that is damaged should be properly repaired or replaced by an authorised service facility unless otherwise indicated in this instruction manual.

Any switch that does not operate correctly must be replaced by an authorised service facility.

DO NOT use the generator if the 'ON / OFF' motor switch does not turn the generator 'ON' and 'OFF'.

PERSONAL SAFETY

CLOTHING

DO NOT wear loose clothing, jewellery or anything that could get caught in moving machinery. Gloves may be worn when filling generator with fuel.

HAIR

Long hair should be tied back or contained in a protective covering.

EYE PROTECTION

The use of safety goggles is highly recommended (normal glasses are not sufficient for eye protection) when using or refuelling generators. Prescription glasses do not have safety lenses.

FOOTWEAR

Where there is the risk of heavy objects or if there is a risk of slipping on wet or slippery floors, suitable non-slip, covered, safety footwear should be worn. Protect your feet from dropping accidents.

EAR PROTECTION

The use of ear protection is highly recommended when using generators. The continual noise may damage your ears.

IMPORTANT SAFETY INSTRUCTIONS

RESPIRATORY PROTECTION

Always wear approved breathing protection when decanting fuel. ALWAYS use this generator in well ventilated area. Never use indoors.



WARNING: DO NOT breathe in exhaust fumes. Exhaust fumes are poisonous and may cause drowsiness, unconsciousness and even death.

DO NOT OVER REACH

Keep a proper footing and maintain your balance at all times. Avoid using abnormal stances and awkward body positions.

STAY ALERT

Watch what you are doing, use common sense, and never operate a generator when you are tired, drinking alcohol, taking drugs or if taking medication that causes drowsiness.

















TECHNICAL SPECIFICATION

AC Output	2 X 230V~50Hz	DC Output	12V DC 5A
AC Output Sockets	2 X 13A	USB Output	2 x 5V DC 2.1A
Rated Power	COP 3.8kW	Oil Type	SAE 10W-30/10W-40
Peak Power	Max. 4.0kW S2 5min	Oil Capacity	600ml
Rated Current	16.5A	Ignition System	T.C.I.
Power Factor	cos ϕ =1	Starting System	Recoil Start
Phase	Single	Spark Plug Type	A7RTC
Displacement	174cc	Weight	25kg
Engine	4 Stroke, OHV	Protection Class	IP23M
No Load Speed	4600min ⁻¹	Performance Class	G1
Run Time (Fuel Tank)	7hrs (50% Load)	Max. Temperature	-15 to 40°C
Fuel Consumption	2 L/hr (100% Load)	Max. Altitude	1000m
Fuel Tank Capacity	7L	Quality Class	A
Fuel Type	Unleaded Petrol	Sound Power Level (4m Away)	96dB(A)

Your product is designed and rated for continuous operation at ambient temperatures up to 40°C. When needed, it may be operated at temperatures ranging from -15°C to 50°C for short periods of time. If exposed to temperatures outside this range during storage, it should be brought back within this range before operation. In any event, the product must always be operated outdoors, in a well-ventilated area and away from doors, windows and vents.

SAFETY SYMBOLS

Some of the following symbols may be used on this product. Please study them and learn their meaning. Proper interpretation of these symbols will allow you to more safely operate the product.

SYMBOL	DESIGNATION/EXPLANATION
	Do not expose to rain or use in damp locations.
	To reduce the risk of injury, the user must read and understand the operator's manual before using this product.
	Always wear safety goggles or safety glasses with side shields and, as necessary, a full face shield when operating this product.
	Precautions that involve your safety.
	Failure to use in dry conditions and to observe safe practices can result in electric shock.
	Running the generator gives off carbon monoxide, an odourless, colourless, poison gas. Breathing carbon monoxide can cause nausea, fainting, or death.
	Fuel and its vapours are extremely flammable and explosive. Fire or explosion can cause severe burns or death.
	To reduce the risk of injury or damage, avoid contact with any hot surface.
	To reduce the risk of serious injury, avoid attempting to lift the generator alone.
	Consult with local electrician to determine grounding requirements before operation.
	Add oil.
	Guaranteed sound power level.
	Beware of electric shock level.
	Fuel and its vapours are explosive and can cause severe burns or death.
	Oil level should fall within the level indicator area on the dipstick.
	Waste electrical products should not be disposed of with household waste. Please recycle where facilities exist. Check with your Local Authority or retailer for recycling advice.
	Conforms to relevant safety standards.

COMPONENTS & CONTROLS

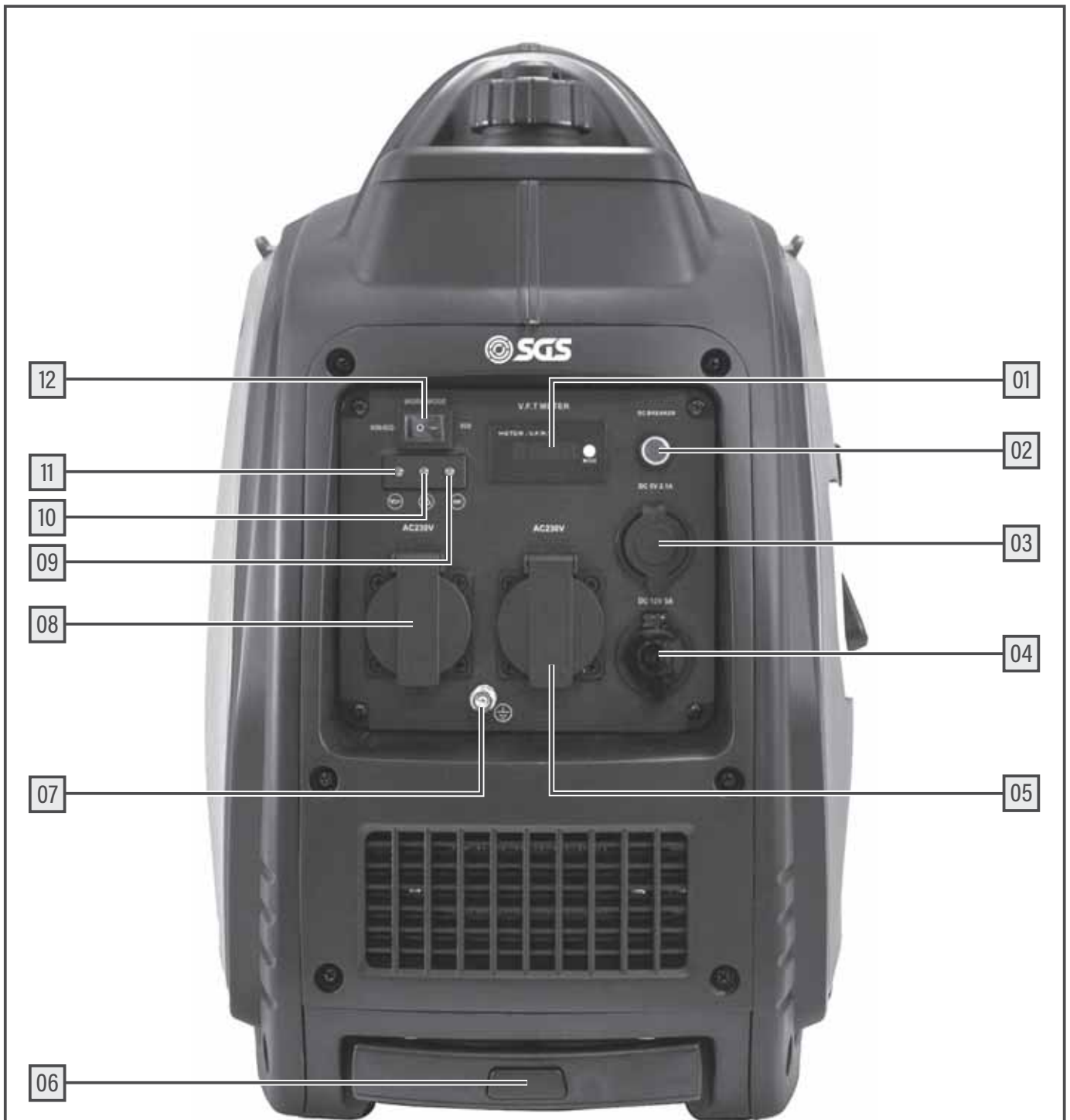

- 01. 3-in-1 voltmeter (V/Hz/Hours)
- 02. DC circuit breaker
- 03. 2 x USB 5V DC, 2.1A ports
- 04. 12V DC, 5A socket
- 05. 230V AC socket, 13A
- 06. Pull-out handle release button

- 07. Ground (earth) terminal
- 08. 230V AC socket, 13A
- 09. AC power output indicator (green)
- 10. Overload indicator (red)
- 11. Oil alert indicator light (yellow)
- 12. Economy control switch

COMPONENTS & CONTROLS



13. Carry handle

14. Engine switch (Stop/Run/Start)

15. Spark plug access panel

16. Fuel tank cap air vent knob

17. Fuel tank cap

18. Recoil starter

COMPONENTS & CONTROLS



19. Access panel screws

20. Access panel for oil filler cap and air filter

21. Air filter

22. Oil filler cap/dipstick

23. Wheel

COMPONENTS & CONTROLS



UNPACKING



CAUTION: This packaging contains sharp objects. Take care when unpacking.

Remove the machine, together with the accessories supplied, from the packaging. Check carefully to ensure that the machine is in good condition and account for all the accessories listed in this manual. Also make sure that all the accessories are complete.

If any parts are found to be missing, the machine and its accessories should be returned together in their original packaging to the retailer. Do not throw the

packaging away, keep it safe throughout the guarantee period, then recycle if possible, otherwise dispose of it by the proper means. Do not let children play with empty plastic bags due to the risk of suffocation. Take care when lifting the compressor from the packaging.



CAUTION: This generator is heavy. Get assistance if necessary. This unit weighs 25kg.

PRE-OPERATION CHECKS

 **WARNING:** Do not use this product if any parts appear to be missing or damaged. Use of a product with damaged or missing parts could result in serious personal injury.

 **WARNING:** Do not attempt to modify this product or create accessories or attachments not recommended for use with this product. Any such alteration or modification is misuse and could result in a hazardous condition leading to possible serious personal injury.

NOTICE: Remove all connected electrical loads before carrying out adjustment, servicing or maintenance.

PACKING CONTENTS

- Inverter generator
- Spark plug socket
- Spark plug socket handle
- Oil measuring jug
- Operator's Manual.

PRE-OPERATION CHECKS

 **WARNING. THIS GENERATOR HAS BEEN SHIPPED WITHOUT ENGINE OIL. DO NOT START THE ENGINE UNTIL IT HAS BEEN FILLED WITH SUFFICIENT ENGINE OIL.**

CHECKING THE ENGINE OIL

 **WARNING.** Running the generator with insufficient engine oil can cause serious engine damage.

Engine oil should be replaced during regular maintenance or when the oil level is below the end of the dipstick.

 **WARNING.** Before checking or replacing oil, make sure the engine is fully stopped and the generator is situated on a stable and level surface.

ADDING ENGINE OIL

Engine oil has a major influence on engine performance and service life. For general, all temperature use, SAE 10W-30 or 10W-40 is recommended. Always use a 4-stroke motor oil. Non-detergent or 2-stroke engine oils will damage the engine and should not be used.

If running the generator in extreme temperatures, refer to the 'Recommended Engine Oil Type' chart below.

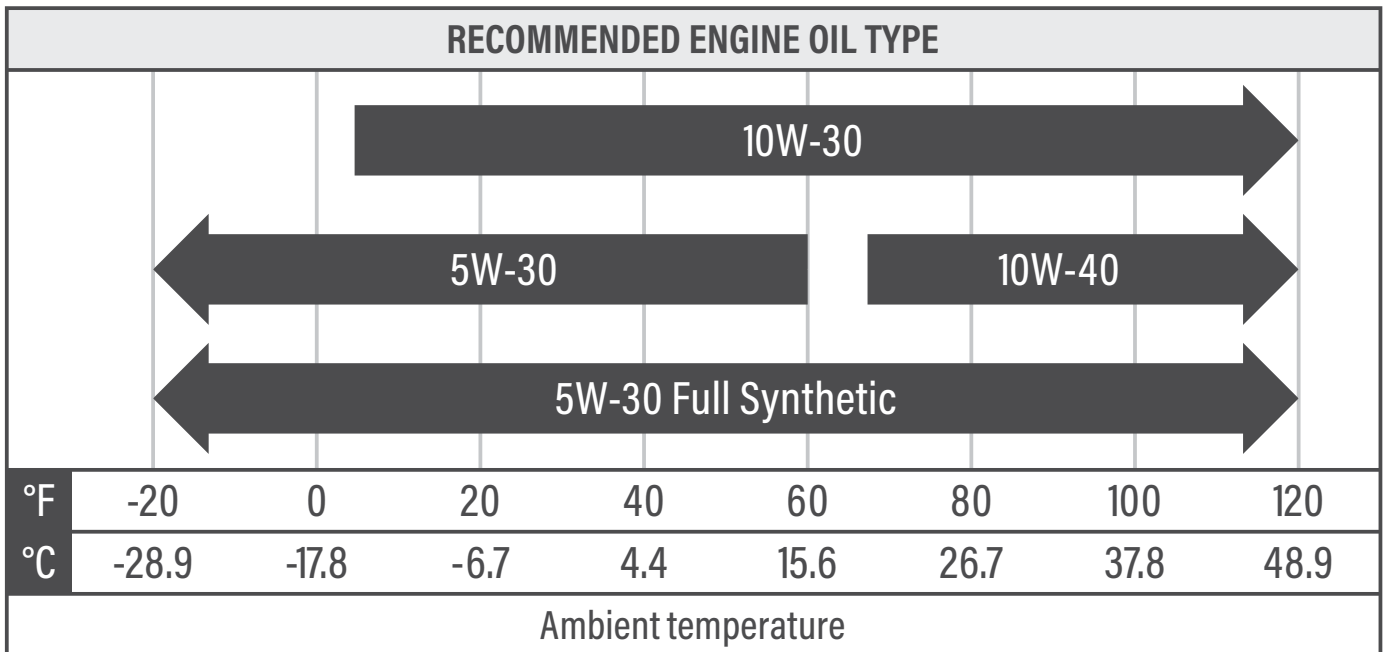

PRE-OPERATION CHECKS

Place the generator on an even surface and unscrew the two access panel screws with a screwdriver (not provided), Fig.1. Remove the panel.



Unscrew the oil filler cap/dipstick by turning anti-clockwise, Fig.2.

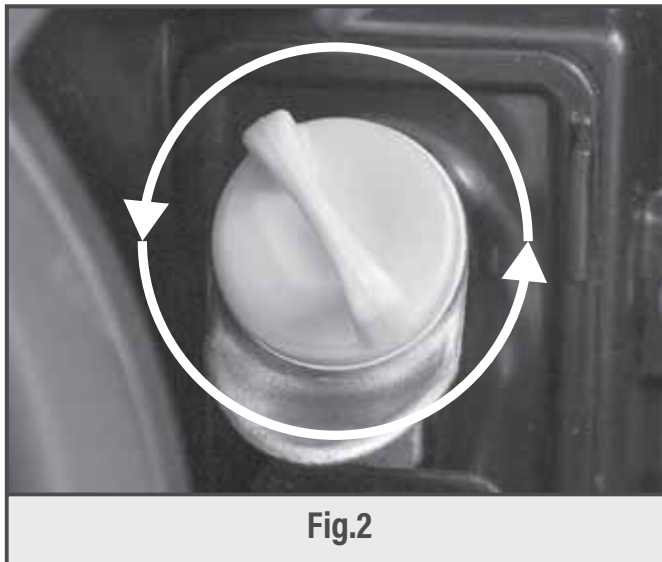

Wipe dipstick clean and re-seat in hole; do not re-thread. Remove dipstick again and check the oil level. The oil level should fall within the level indicator area on the dipstick. If level is low, add engine oil with the funnel until the fluid level rises to the top of the oil filler neck, Fig.3.



WARNING. DO NOT OVERFILL THIS UNIT WITH OIL.

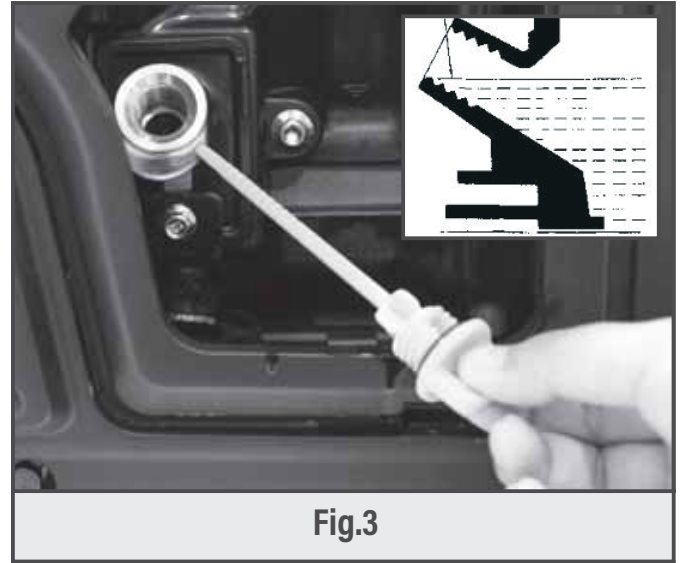

Engine oil has a major influence on engine performance and service life. Use high-detergent, premium quality 4-stroke engine oil SAE 10W-30 or SAE 10W-40 only.

Oil capacity: 600ml



WARNING. Non-detergent and 2-stroke engine oils will damage the engine and are not recommended.

Replace and secure the oil cap/dipstick.

NOTICE. Check the engine oil level at every use and add as needed.

USING FUEL STABILISER

Fuel gets old, oxidises, and breaks down over time. Adding a fuel stabiliser (not included) extends the usable life of fuel and helps prevent deposits from forming that can clog the fuel system. Follow fuel stabiliser manufacturer's directions for correct ratio of stabiliser to fuel.

Mix fuel stabiliser and petrol prior to filling the tank by using a petrol can or other approved fuel container and shaking gently to combine.

NOTICE. To control the amount of fuel stabiliser being added to the engine, always mix fuel stabiliser with petrol before fueling the tank rather than adding fuel stabiliser directly into the generator's fuel tank.

PRE-OPERATION CHECKS

Replace and secure the fuel tank cap.

Start and run the engine for at least 5 minutes to allow stabiliser to treat the entire fuel system.

OXYGENATED FUELS



WARNING! Do not use E15 or E85 fuel (or fuel containing greater than 10% ethanol) in this product. It will damage the unit and void your warranty.

Fuel system damage or performance problems resulting from the use of an oxygenated fuel containing more than the percentage of oxygenates stated below are not covered under warranty.

Ethanol. Gasoline containing up to 10% ethanol by volume (commonly referred to as E10) is acceptable. E15 and E85 are not.

CHECKING/ADDING FUEL



DANGER! STOP engine before adding fuel. This engine is certified to operate on unleaded petrol. Unleaded petrol produces fewer engine and spark plug deposits and extends exhaust system life.



WARNING! Never use stale or contaminated petrol or an oil/petrol mixture. Avoid getting dirt or water in the fuel tank.

Petrol is extremely flammable and explosive under certain conditions. Do not smoke or allow flames or sparks where the generator is refuelled or where petrol is stored.

When adding petrol to the generator, make sure the unit is sitting on a flat, level surface. If the engine is hot, let the generator cool before adding fuel. ALWAYS fill the fuel tank outdoors with the machine turned off.

Remove the fuel cap by turning anti-clockwise, Fig.4.

Slowly fill the tank with unleaded petrol. The fuel tank should not be filled above the top of the fuel filter, Fig.5.

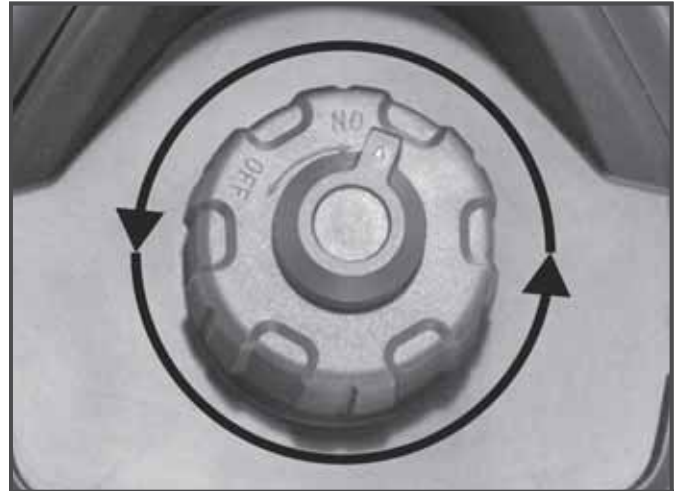

Fig.4

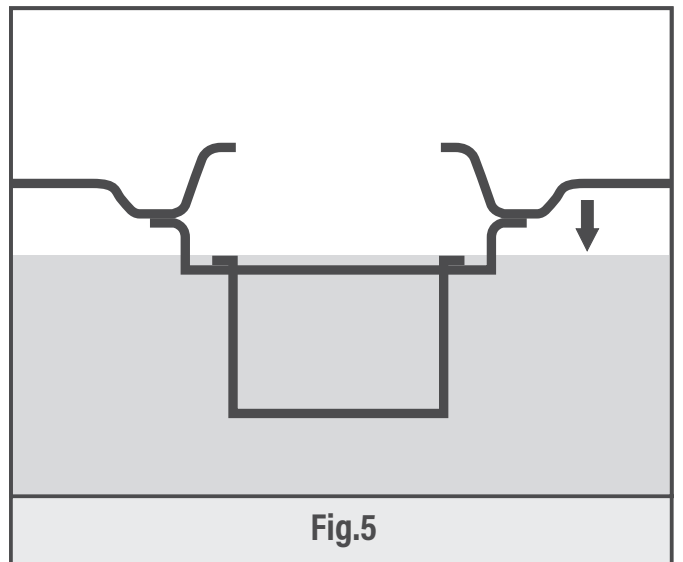

Fig.5

Replace and secure the fuel cap. Never use old, stale, or contaminated unleaded fuel, and do not use an oil/fuel mixture. Do not allow dirt or water into the fuel tank.

Refuel in a well-ventilated area.

Do not let fuel spill over the generator casing. If there is some fuel spillage, be sure that it has evaporated before starting the engine.

Avoid touching gasoline or breathing in gasoline fumes.

LOCATION & GROUNDING

Before using this generator it must be prepared correctly before use. Locate the generator on firm level ground away from buildings or other structures ensuring that the exhaust is not obstructed.



WARNING! It is advisable to properly earth-ground your generator before starting using a wire and a small earth stake.

Note: The wire and earth stake are not supplied with the unit.

Earth spike and cable can be purchased at your local camping supplies, or alternatively an earth spike can be made, and it is suggested you get advice from a registered electrical trades person. To make a spike use a copper tube or copper rod 12mm diameter, a minimum length of 200mm and with an M6 machine screw one end. The cable used should be a maximum length of 1 metre and a minimum of 1.0mm² to carry a 10amp load. The cable should be attached to the generator at the ground (earth) terminal (Fig.6) and to the spike between a flat washer and the copper with a lock washer under the head of the M6 Machine screw in a similar fashion to the earth point screw on the generator.



When placing the spike into the ground the generator must not be running and it is suggested that the spike is pushed into the ground by at least 100mm so that it is firm and a litre of water poured around it to ensure good earth continuity.

All electrical tools and appliances operated from this generator must be properly grounded by use of a third wire or be "Double Insulated."

It is recommended to:

1. Use electrical devices with 3-prong grounded plugs.
2. Use an extension cord intended for outdoor use with a 3-pole receptacle and a 3-prong plug at opposite ends to ensure continuity of the ground protection from the generator to the appliance.

Check and adhere to all applicable local regulations relating to grounding specifications. Consult a qualified electrician or service personnel if the grounding instructions are not completely understood or if in doubt as to whether the generator is properly grounded.

UNDERSTANDING THE CONTROL PANEL



1. The 3-in-1 voltmeter displays the voltage (V), frequency (Hz) and usage time (Hours). The values appear by successively pressing the "MODE" button.
2. DC circuit breaker. The circuit breaker is provided to protect the generator against electrical overload.
3. USB 5V DC, 2.1A ports. Power your smartphone, tablet, laptop etc.
4. 12V DC, 5A socket. For charging or powering 12V devices like car batteries or small appliances.
5. 230V AC, 13A socket. May be used to supply electrical power for operation of 230 Volt AC, 13A, single phase, 50Hz electrical loads.
6. Ground (earth) terminal (See page 18).
7. 230V AC, 13A socket. May be used to supply electrical power for operation of 230 Volt AC, 13A, single phase, 50Hz electrical loads.
8. AC power output indicator light (green). Indicates that the generator is producing electrical power at the sockets.
9. If the generator is overloaded (in excess of 3800W), or if there is a short circuit in a connected appliance, the engine overload indicator light (red) will go ON. The engine overload indicator light (red) will stay ON, and after several seconds, current to the connected appliance(s) will shut off, and the AC power indicator light (green) will go OFF.
10. The Oil alert system is designed to prevent engine damage caused by an insufficient amount of oil in the crankcase. Before the oil level in the crankcase can fall below a safe limit, the Oil Alert indicator light (yellow) comes on and the Oil Alert system automatically will stop the engine (the engine On/Off switch will remain in the ON position). If the engine stops or the Oil Alert indicator light comes on when you pull the starter grip, check the engine oil level.
11. Economy control switch. When turned to the ON position the economy control unit controls the engine speed according to the connected load. The results are better fuel consumption and less noise.

OPERATION

BEFORE OPERATING THE UNIT

Only use OUTSIDE and far away from windows, doors, and vents.

NEVER use inside a home or garage, even if doors and windows are open.

Always position the generator on a flat firm surface.

NOTICE: If location of generator is not level, the unit may not start or may shut down during operation.



WARNING: Do not operate or store the generator in wet weather conditions such as rain or snow. Using the generator in wet conditions could result in serious injury or death due to electrocution.

STARTING THE GENERATOR



CAUTION! Always check the oil and fuel level before starting the engine, see Page 15 to 17.

Before starting the engine make sure that all the electrical loads are disconnected from the generator AC outlet socket.

If you are using the generator for the first time or it has been stored away for a long time, the engine switch should be opened for ten or twenty seconds to allow fuel to enter the carburettor.

Open the fuel tank cap air vent knob to the ON position (Fig.7).



Fig.7

NOTICE: When transporting the generator, turn the fuel tank cap air vent knob to the OFF position.

Turn the engine switch to the START position, Fig.8.



Fig.8

Hold down the generator firmly with one hand on the handle. With the other hand grip the recoil starter cord handle, Fig.9, and pull and return the rope gently 3-4 times to let the engine breathe in the fuel mixture from the carburetor. Pull the cord sharply. Continue this procedure until the engine starts.



Fig.9



CAUTION. Avoid damaging the plastic case of the crankshaft while pulling the rope. Always return the recoil starter cord handle slowly.

OPERATION

When the engine has been successfully started and is running smoothly turn the engine switch to the RUN position, Fig.10.

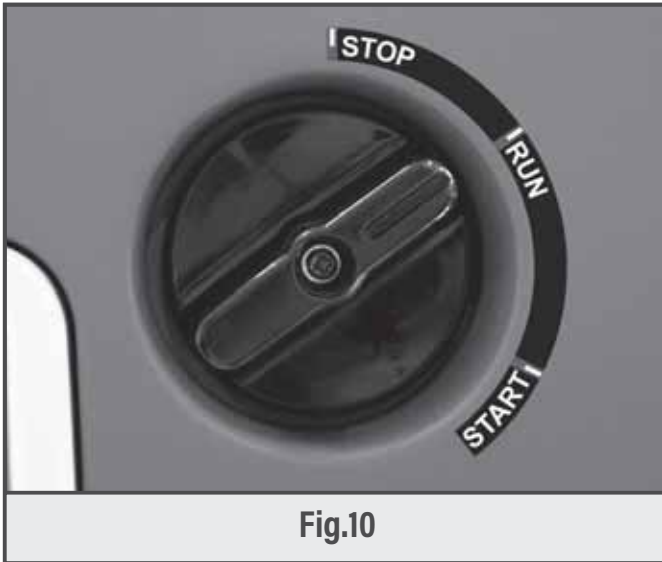

Fig.10

Before connecting any electrical load to the generator ensure that the load does not exceed the maximum load as stated on the rating plate.

Ensure that the mains supply lead is long enough to reach the generator without any strain.

When the generator engine has been successfully started and is running smoothly connect the electrical load to the generators AC output socket.

ECONOMY CONTROL SWITCH (FIG.11)

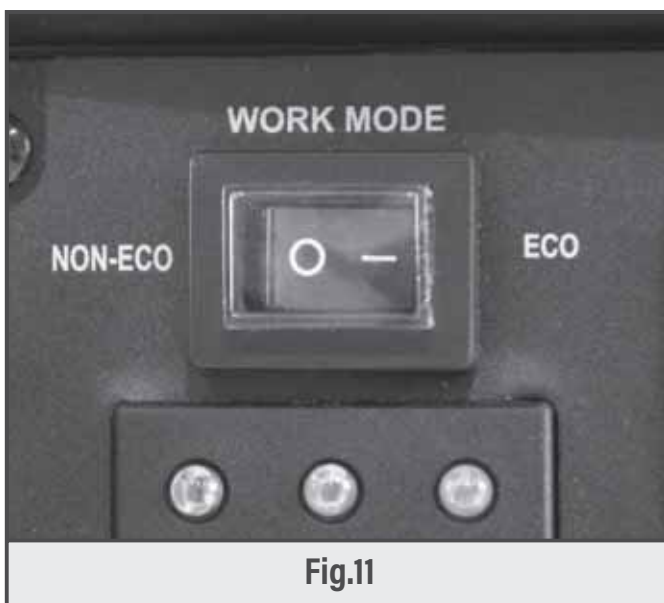

Fig.11

ECO: Recommended to minimise fuel consumption and further reduce noise levels when no load is applied to the generator.

NON-ECO: The smart throttle system does not operate. Engine speed varies with the load.

With the switch in the ECO position, the engine speed is controlled automatically. The engine speed is lowered when the load on the generator is reduced, turned off or disconnected. When loads are turned on or re-connected, the engine returns to the correct speed to power the connected load.

In the NON-ECO position the system does not operate. The economy system also helps in fuel economy and reduced noise levels when under no load conditions.

When a load is connected to the generator, the generator speed will automatically adjust in order to supply enough power.

Appliances with large start-up power demands may not allow the engine to reach normal operating speed when they are connected to the generator. Turn the economy switch to the NON-ECO position and connect the appliance to the generator. If the engine still will not reach normal operating speed, check that the appliance does not exceed the rated load capacity of the generator.

AC OUTLETS

Your generator is equipped with two 230V AC power sockets. These will run a range of devices providing they are within the limits of the generators output.

NOTICE: The max (surge) power requirements of some devices e.g. Fridges, Televisions, etc; can be up to seven (7) times greater than their rated (continuous) power. Do not over load your generator. The devices wattage can be found on the data label attached to the product.

OPERATION

A basic guide is shown below for some common products. You can use any combination of appliances provided that you do not exceed the limits of your generator. For this generator never exceed 3800W in total when combining multiple different appliances.

NOTICE: When using multiple devices only start one device at a time.

YOUR GENERATOR AC LIMITS

Rated (continuous) power - COP 3.8kW

Max (surge) power - MAX 4.0kW S2 5min

NOTICE: Long extension leads may reduce the effectiveness of your generators supply power.

DOMESTIC APPLICATIONS	APPROX. STARTING WATTAGE	APPROX. RUNNING WATTAGE
Fridge or Freezer	1200W	130-200W
650W Microwave	1000W	1000W
800W Microwave	1300W	1300W
1000W Microwave	1500W	1500W
House Lights	As stated on bulb (e.g 60W)	As stated on bulb (e.g 60W)
30" Flat Screen Television	120W	120W
50" Flat Screen Television	190W	190W
Dishwasher	540W	220W
Vacuum Cleaner	800W	800W
Electric Fry Pan	1500W	1500W
Electric Range (20cm)	2100W	2100W
Dryer	6750W	5400W
Laptop	250W	250W
Desktop Computer	800W	800W
Computer Monitor	30W	30W
Hot Water Heater	4500W	4500W
Garage Door Opener	1420W	720W
1600W Hair Dryer	1900W	1800W
Campervan Fridge	600W	180W
Slow Cooker	250W	250W
DVD Player	350W	350W
Portable Fan	120W	40W

OPERATION

INDUSTRIAL APPLICATIONS	APPROX. STARTING WATTAGE	APPROX. RUNNING WATTAGE
0.5HP Air Compressor	1600W	975W
1HP Air Compressor	4500W	1600W
20cm Bench Grinder	2500W	1400W
185mm Circular Saw	2300W	1400W
Demolition Hammer	1260W	1260W
355mm Electric Chainsaw	1100W	1100W
Hand Drill	900W	600W
1HP High Pressure Washer	3600W	1200W
Rotary Hammer Drill	3600W	1800W
10" Table Saw	4500W	1800W

You can use any combination of appliances provided that you do not exceed the limits of your generator. For this generator never exceed 3800W in total when combining multiple different appliances

STOPPING THE GENERATOR



WARNING. In case of emergency, the easiest way to stop the generator is to directly put engine switch to the STOP position. Avoid doing so in non-emergency circumstances as it carries the risk of damaging the generator.

1. Before stopping the engine make sure that all the electrical loads are disconnected from the generator AC outlet sockets.



WARNING. After disconnecting all loads, leave the generator running for another 1-2 minutes before shutting it down. Then switch off the engine switch. Switching off the engine with loads attached may damage the unit and cause difficulty starting the generator next time it is used.

2. Switch off the engine by putting the engine switch in the STOP position, Fig.12.



Fig.12

OPERATION

- Turn the fuel tank cap air vent knob to the OFF position.

12V DC 5A SOCKET



WARNING. The 12V DC socket is designed for charging or powering 12V devices like car batteries or small appliances. Charge vented wet lead acid batteries ONLY. Other types of batteries may burst, causing personal injury and damage.

NOTICE: The 12V DC socket provides continuous charge. Do not overcharge battery or leave battery unattended. Doing so may cause damage to the battery.

NOTICE: Do not use the generator to jump start vehicles. Doing so could result in damage to the vehicle or it's electrical components.

Using battery clamps with a compatible cigarette lighter adaptor socket (not supplied), connect the battery charging cable assembly to the battery terminal. Connect the red wire to the positive (+) terminal first, then connect the black wire to the negative (-) terminal. Make sure all connections are secure.

NOTICE: Be careful not to short across the terminals when installing. Shorting the terminals together can cause sparks, damage to the battery or generator, or even burns or explosions.

Connect the battery charging cable assembly to the 12V DC socket, Fig.13. and twist to the left or right to lock in place.



Fig.13

Start the generator.

NOTICE: Ensure the Economy switch is turned off while charging batteries.

NOTICE: The AC receptacles can be used while the DC receptacle is in use.

Using a hydrometer measure the specific gravity of the battery fluid and calculate the charging time in accordance with the table shown, Fig.14.

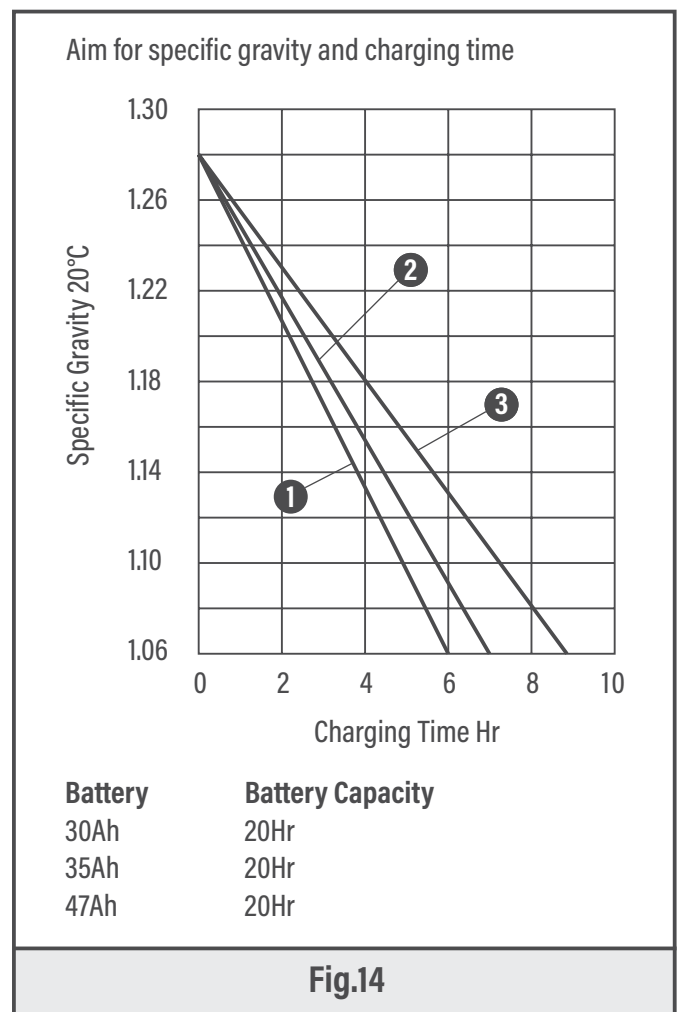

The battery will become slightly warm to the touch while charging. This is normal and does not indicate a problem.

The DC circuit breaker turns off automatically if the current exceeds the rated flow during battery charging. To restart the battery charging process press the circuit breaker button to ON, Fig.15.

OPERATION

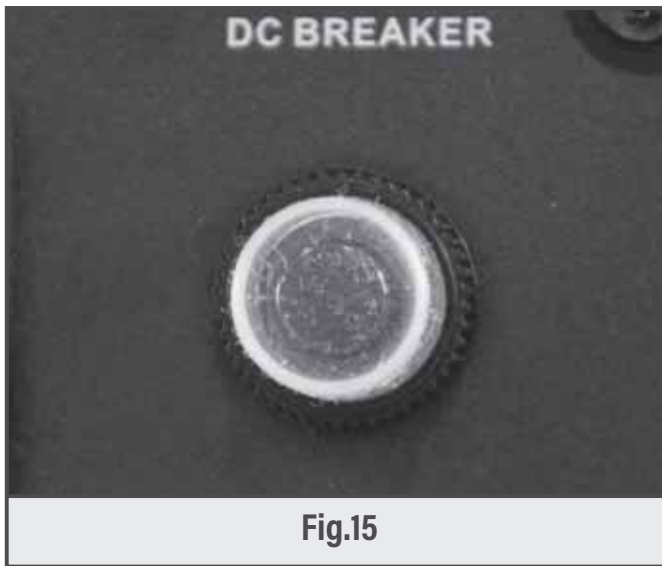

NOTICE: Only use your battery charging cable assembly to charge vented wet lead acid batteries.

When batteries become fully charged, disconnect the battery charging cable assembly from the battery. Disconnect the negative (black) wire first, then the positive (red) wire, being careful not to short across the terminals. Always abide by the safety warnings provided with the battery.

NOTICE: The specific gravity for the fully charged battery shall be within 1.26 to 1.28. It is advisable to check the specific gravity every hour. It is highly recommended that you refer to your battery manufacturer's instructions for specific charge times.

Unplug battery charging cable assembly and store for later use.



WARNING: Never smoke or make/break the connections at the battery while charging. Sparks can ignite the battery gas.

Battery electrolyte is poisonous and dangerous and can cause severe burns. Avoid contact with skin, eyes and clothing.

5V DC 2.1A USB SOCKETS

This generator has two USB C outputs for the fast charging of mobile phones, tablets, laptops etc.

They USB ports are accessible after lifting the waterproof cap, Fig.16.

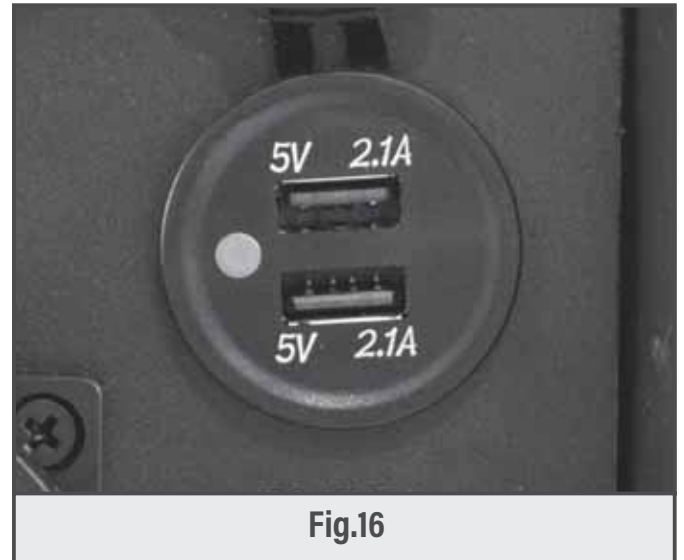

3-IN-1 VOLTMETER (FIG.17)

The digital voltmeter displays the voltage (V), frequency (Hz) and usage time (Hours). The values appear by successively pressing the "MODE" button.



OVERLOAD PROTECTION (FIG.18)

NOTICE: Under normal working conditions the AC power output indicator will be illuminated GREEN.

OPERATION

If the generator is overloaded or if there is a malfunction or a short circuit in a connected appliance, the (GREEN) AC power output indicator will extinguish and the (RED) overload indicator light illuminates and the power to the connected appliance will be disconnected.

If the (RED) overload indicator light illuminates stop the generator and investigate the cause.

Before connecting an appliance to the generator, check that it is in good order, and that its electrical rating does not exceed that of the generator. Then connect the power cord of the appliance and start the engine.

When an electric motor is started, both the (RED) overload indicator and the (GREEN) AC power output indicator will illuminate simultaneously. This is normal, the (RED) overload indicator extinguishes after about four (4) seconds. If the (RED) overload indicator remains illuminated, consult your generator dealer.

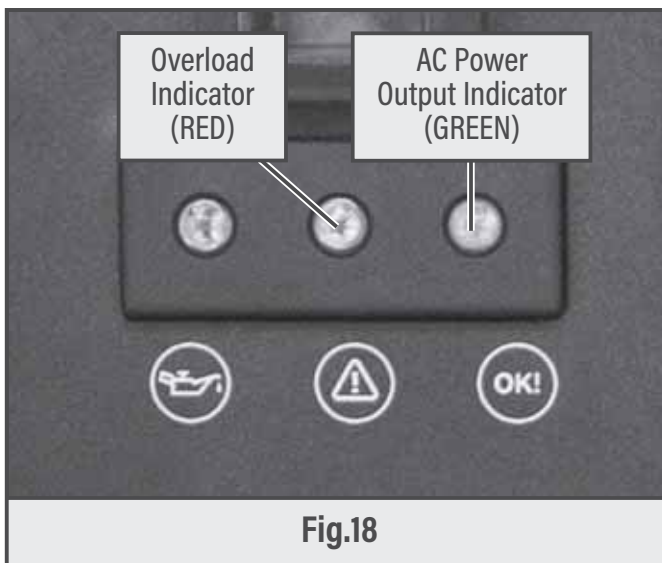

WARNING. Substantial overloading that continuously illuminates the (RED) overload indicator may damage the generator. If the (RED) overload indicator light and the (GREEN) AC power output indicator illuminate at the same time when engine starts and the (RED) overload indicator remains illuminated after the (GREEN) AC power output indicator extinguishes, please contact your supplier.

NOTICE: For equipment with an inductive load (more power will be required at initial start). Under these conditions it is normal for both the (RED) overload indicator and the (GREEN) AC power output indicator will illuminate simultaneously for a short period about four (4) seconds. After the appliance starts, the (RED) over-load indicator extinguishes and the (GREEN) AC power output indicator will remain illuminated.

HIGH ALTITUDE OPERATION

Specific modifications are needed for high-altitude operation. Please contact your authorised service centre for important information regarding these modifications. Operating this engine without the proper altitude modification may increase the engine's emissions and decrease fuel economy and performance.



CAUTION: If the carburettor has been modified for high altitude operation, the air-fuel mixture will be too lean for low altitude use. Operation at low altitude may cause the engine to overheat and result in serious engine damage. The carburettor will need to return to its original specification.

MAINTENANCE

MAINTENANCE



WARNING: When servicing, use only identical replacement parts. Use of any other parts could create a hazard or cause product damage.



WARNING: Always wear eye protection with side shields marked to comply with ANSI Z87.1. Failure to do so could result in objects being thrown into your eyes, resulting in possible serious injury.

Keep the generator in a clean and dry environment where it is not exposed to dust, dirt, moisture, or corrosive vapours.

Do not allow the cooling air slots in the generator to become clogged with foreign material such as leaves, snow, etc.

Do not use a garden hose to clean the generator. Water entering the fuel system or other internal parts of the unit can cause problems that will decrease the life of the generator.

To clean the unit:

1. Use a soft bristle brush and/or vacuum cleaner to loosen and remove dirt and debris.
2. Clean air vents with low pressure air that does not exceed 25 psi.
3. Wipe the exterior surfaces of the generator with a damp cloth.

CHECKING/CLEANING THE AIR FILTER

For proper performance and long life, keep air filters clean. A dirty air filter will restrict air flow to the carburettor. After every 50 hours of running the air filter should be removed and examined for deterioration and cleaned.



WARNING: Using gasoline or flammable solvent to clean the air filter can cause a fire or explosion. Use only soapy water or a non flammable solvent.

Unscrew the two access panel screws with a screwdriver (not provided), Fig.19.

Remove the panel and set aside.



Loosen the air filter cover fastening knob in the centre of the air filter cover anti-clockwise, Fig.20.



Pull the cover away and off the unit and set aside.

MAINTENANCE

Remove the air filter, Fig.21.

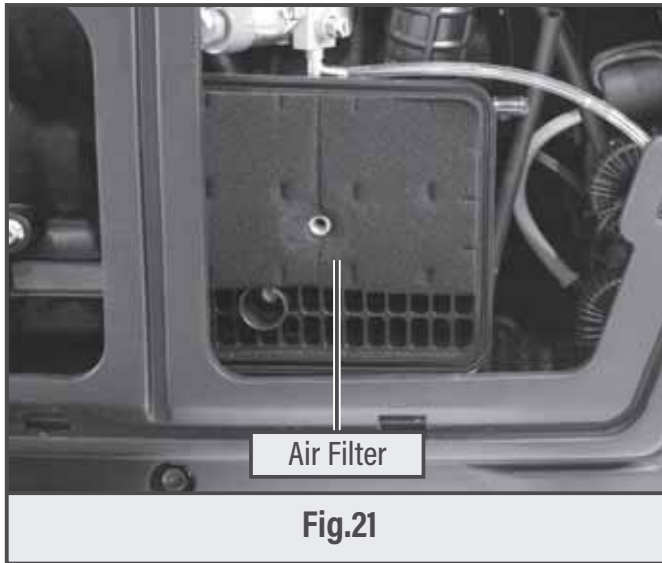

Wash the air filter in a solution of household detergent and warm water, then rinse thoroughly, or wash it in a non flammable or high flash point solvent. Allow the air filter to dry thoroughly.

Reinstall the air filter cover. Tighten the air filter cover fastening knob clockwise to secure.

Reinstall the access panel. Tighten the two screws to secure.

ENGINE OIL REPLACEMENT

For best performance, engine oil should be changed after every 100 hours or 6 months of operation.

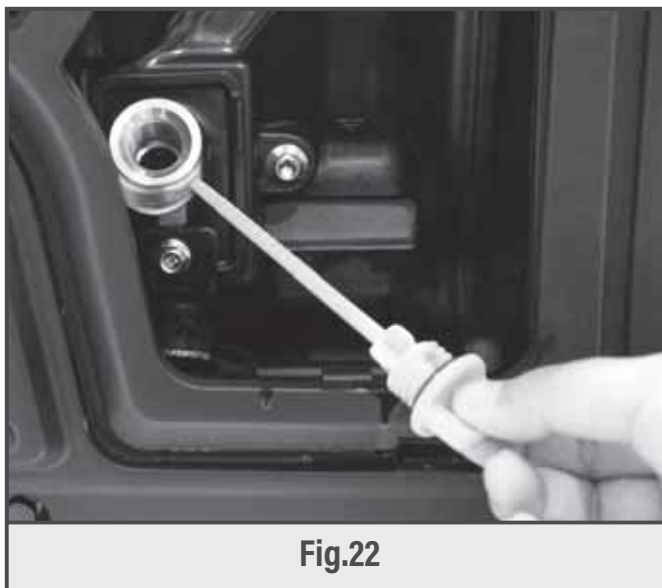

Unscrew the two access panel screws with the screwdriver provided. Remove the panel and set aside.

Remove the oil filler cap/dipstick, Fig.22.

Place a suitable container under the engine to catch the used oil.

Tilt the generator to the side and allow oil to drain from the oil fill hole into the container.

NOTICE: Drain the oil while the engine is still warm but not hot. Warm oil will drain quickly and more completely.



WARNING: Do not change engine oil while it is hot. Accidental contact with hot engine oil could result in serious burns.

Return the generator to an upright position and refill with oil following the instructions in the ADDING ENGINE OIL section on pages 15 to 16.

Use high-detergent, premium quality 4-stroke engine oil SAE 10W-30 or SAE 10W-40 only.

Oil capacity: 600ml.

Replace and secure the oil filler cap/dipstick.

Reinstall the access panel. Tighten the two screws to secure.

NOTICE: Improper disposal of engine oil can be harmful to the environment. If you change oil please dispose of it properly. Put it in a sealed container and take it to a recycling centre. Do not discard it in household waste, dump it on the ground or pour it down a drain.

SPARK PLUG REPLACEMENT

To ensure proper engine operation, the spark plug must be properly gapped and free of deposits.

Remove the spark plug access panel, Fig.23.

Pull the HT lead off the spark plug, Fig.24, and clean any dirt from around the spark plug base. Using the wrench supplied remove the spark plug, Fig.25.

MAINTENANCE



Fig.23



Fig.24



Fig.25

Visually inspect the spark plug. Discard it if the insulator is cracked or chipped.

Please use a spark plug gauge to check the spark plug gap, it should be 0.6-0.7mm (0.024-0.028 inch).

NOTICE: If replacing, use the following recommended spark plug: A7RTC.

Check that the spark plug sealing washer is in good condition, and thread the spark plug in by hand to prevent cross threading.

After the spark plug is seated, tighten with a spark plug wrench to compress the washer. If installing a new spark plug, tighten 1/2 turn after the spark plug seats to compress the washer. If reinstalling a used spark plug, tighten 1/8 - 1/4 turn after the spark plug seats to compress the washer.

Reinstall the HT lead on the spark plug securely.

Reinstall the spark plug access panel.



WARNING: Spark plug must be assembled firmly, or it will become hot and may damage the generator.

A loose spark plug can overheat and damage the engine.

NOTICE: Be careful not to cross-thread the spark plug. Cross-threading will damage the product.

FUEL TANK FILTER (FIG.26)



Fig.26

MAINTENANCE

After every 100 hours of running or every 6 months the fuel tank filter should be removed and cleaned.

Remove the fuel tank filler cap and the filter, clean the filter thoroughly using an environmentally friendly water based degreasing agent and re-fit.

DRAINING FUEL TANK/CARBURETTOR

To help prevent gum deposits in the fuel system, drain the fuel from the tank and carburettor before storing.

DRAINING THE FUEL TANK

NOTICE: Remove all oil from the unit before draining the fuel tank. Failure to do so could cause damage to the unit.

Remove the fuel cap.

Tilt the generator and allow fuel to drain from the fuel tank into an approved container.

When the fuel has drained from the tank, replace the fuel cap and immediately wipe off any spilled fuel with a clean, dry soft cloth as petrol can deteriorate painted surfaces and plastic parts.

DRAINING THE CARBURETTOR (FIG.27)

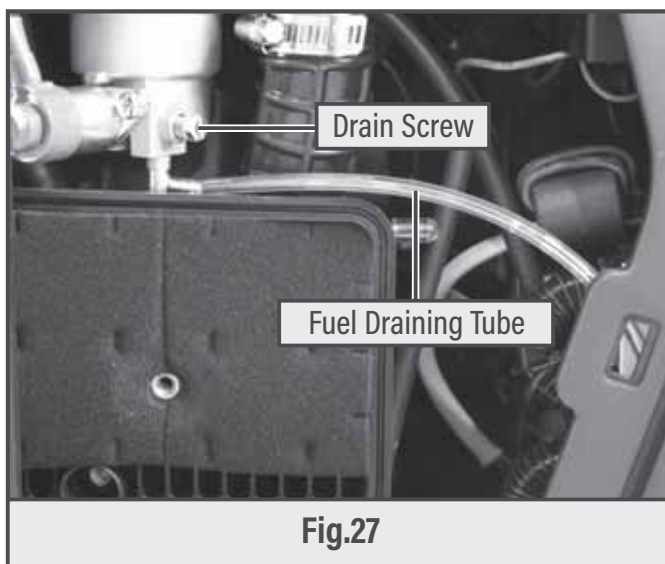

Loosen the two screws at the top of the access panel. Remove cover and set aside.

Open the fuel tank cap air vent knob to the ON position.

Turn the engine switch to the ON position.

Locate the tube attached to the carburettor and place the end of the tube into a suitable container.

Loosen the drain screw, Fig.27.

Take off the spark plug cap, pull the starter grip three or four times, discharge the gasoline from the fuel pump

Allow fuel to drain completely into container.

Turn the engine switch to the OFF position and retighten the drain screw securely.

Place the fuel tank cap air vent knob to the OFF position.

Reinstall the spark plug cap.

NOTICE: Consult hazardous waste management guidelines in your area for the proper way to dispose of used fuel.

CLEANING THE EXHAUST PORT & MUFFLER

Depending on the type of fuel used, the type and amount of oil used, and/or your operating conditions, the exhaust port and muffler may become blocked with carbon deposits. If you notice a power loss with your petrol-powered tool, you may need to remove these deposits to restore performance. We highly recommend that only qualified service technicians perform this service.

MOVING THE GENERATOR

Never lift or carry the generator using the pull-out handle.

Never tilt sideways while moving the generator.

Always place the generator on its wheels in the upright position.

Always turn off the generator. Ensure the engine switch is in the STOP position and the fuel tank cap air vent knob is in the OFF position.

Always make sure the engine and muffler are cooled down before the generator can be handled safely (typically 15-30 minutes).

MAINTENANCE



WARNING: The pull-out handle is not long enough to hold and walk with a full stride when moving the generator. Always side step as you walk to avoid injury to your heels and/or feet. Failure to follow these instructions could result in personal injury or damage to the generator.

1. Begin by pressing the pull-out handle release button, found at the bottom of the front panel of the generator.
2. Pull out the handle to its full extent.
3. Using the handle, tilt the end of the generator slightly off the ground until balanced on the wheels, Fig.28.



Fig.28

3. While maintaining balance, roll the generator to the desired location.

STORAGE

If the generator is not to be used or is to be stored for more than one month the following storage procedure should be carried out. Drain all the fuel from the fuel tank and the carburettor, ensure that all the fuel has been removed. Remove the spark plug and pour approximately one tablespoon full of clean engine oil into the spark plug hole. With the ignition turned OFF gently pull on the recoil starter cord several times. Re-fit the spark plug and continue to pull the recoil starter cord until the piston is on the compression stroke (when resistance is felt) then stop pulling.

Store the generator in a dry well ventilated place under a cover to prevent any dust or debris from accumulating on the generator.

When preparing the generator for storage, follow the storage chart below.

STORAGE TIME	PRIOR TO STORING
Less than 1 month.	No special preparation is required.
1 to 2 months.	Empty fuel from the fuel tank.
2 months to 1 year.	Empty fuel from the fuel tank. Clean fuel from the carburettor. Clean fuel sediment cup.
1 year or more.	Empty fuel from the fuel tank. Clean fuel from the carburettor. Clean fuel sediment cup. Remove spark plug. Put a tablespoon of engine oil into the cylinder through the spark plug hole. Turn the engine slowly with the pull rope to distribute the oil. Reinstall spark plug. Change engine oil.
Use unleaded fuel stabilisers formulated to extend storage life. For recommendations, contact your nearest authorised service centre.	

SERVICE

Now that you have purchased your tool, should a need ever exist of repair or service, simply contact your nearest SGS Engineering Authorised Service Centre or other qualified service organisation. Be sure to provide all pertinent facts when you call or visit.

MAINTENANCE CHART

ITEM	REMARK	PRE-OPERATION CHECK (DAILY)	INITIAL 1 MONTH OR 20 HOURS	EVERY 3 MONTHS OR 50 HOURS	EVERY 6 MONTHS OR 100 HOURS	EVERY 12 MONTHS OR 300 HOURS
Spark plug	Check condition. Adjust gap and clean. Replace if required			■		
Engine oil	Check oil level.	■				
	Replace.		■		■	
Air filter	Clean. Replace if required.			■		
Fuel filter	Clean fuel cock filter. Replace if required.				■	
Valve clearance	Check and adjust when engine is cold.					■
Fuel line	Check fuel hose for cracks or damage. Replace if required.	■				
Exhaust system	Check for leakage. Tighten or replace gasket if required.	■				
	Check exhaust screen. Clean and replace if required.				■	
Carburettor	Check choke operation.	■				
Cooling system	Check fan damage.					■
Starting system	Check recoil starter operation.	■				
Decarbonisation	More frequently if necessary.					■
Fittings / Fastenings	Check all fittings and fixtures and tighten if required.				■	

TROUBLESHOOTING

PROBLEM	CAUSE	SOLUTION
Generator will not start.	No fuel.	Add fuel.
	Faulty spark plug.	Replace spark plug.
	Engine switch is set to OFF.	Set engine switch to START.
	Low oil level.	Fill crankcase to the proper level.
	Engine is filled with contaminated or old fuel.	Drain fuel in the tank. Fill with fresh fuel.
Engine runs but there is no electrical output.	Overload indicator is tripped due to wattage overload.	Check the total wattage of the devices and reduce the load if it exceeds the capacity of the generator.
	Cable not properly connected.	Check all connections.
	Connected device is defective.	Try connecting a different device.
Generator runs but does not support all electrical devices connected.	AC or DC receptacles are overloaded, overload indicator is tripped.	Check the amperage of the devices to make sure they are within the capacity of the receptacles.
	Short circuit in one of the devices.	Disconnect any faulty or short-circuited electrical loads.
	Air filter is dirty.	Clean or replace the air filter element.
Generator shuts down during operation.	Out of fuel.	Fill fuel tank.
	Low oil level.	Fill crankcase to the proper level. Place generator on a flat, level surface.
Engine RPM is fluctuating during operation.	The fuel isn't running through the fuel valve.	Turn off the generator and wait for it to cool down. Check if the fuel is properly and consistently going through the fuel valve.
	The air filter is clogged.	Check for any blockage in the air filter. Check and clean the air filter as necessary.
	The muffler or spark arrester is blocked.	Check if the spark arrester is blocked. Clean with metal brush as necessary.

ENVIRONMENTAL PROTECTION

Information for (private householders) for the environmentally responsible disposal of Waste Electrical and Electronic Equipment (WEEE)



This symbol on products and or accompanying documents indicates that used and end of life electrical and electronic equipment should not be disposed of in household waste. For the proper disposal, treatment, recovery and recycling, please take these products to designated collection points, where they will be accepted on a free of charge basis. Alternatively, in some countries you may be able to return your products to your retailer upon the purchase of an equivalent new product. Disposing of this product correctly will help to save valuable resources and prevent any potential adverse effects on human health and the environment which could otherwise arise from inappropriate waste disposal and handling. Please contact your local authority for further details of your nearest designated collection point. Penalties may be applicable for incorrect disposal of this waste in accordance with national legislation.

FOR BUSINESS USERS IN THE EUROPEAN UNION.

If you wish to discard electrical and electronic equipment, please contact your dealer or supplier for further information.

Information on Disposal in other Countries outside the European Union.

This Symbol is only valid in the European Union.

If you wish to dispose of this product, please contact your local authorities or dealer and ask for the correct method of disposal.



SIG4
4.0kW Inverter Petrol Generator

**WARNING! DO NOT OVERFILL
THIS UNIT WITH OIL**

**FILL WITH 600ML OF
SAE 10W-30 or
10W-40 4-STROKE
ENGINE OIL ONLY.**

The oil level should fall within the level indicator area on the dipstick.
Overfilling this generator with oil will cause serious damage
and will invalidate your warranty.

EC DECLARATION OF CONFORMITY

1. Product model: SIG4
2. Name and address of the manufacturer or his authorised representative:



SGS Engineering (UK) Ltd
Unit 1 West Side Park, Raynesway, Derby, DE21 7AZ
Telephone: +44 (0)1332 576 850

3. This declaration of conformity is issued under the sole responsibility of the manufacturer.
4. Object of the declaration:
Equipment: 4.0kW Inverter Petrol Generator
Brand name: SGS
Model/type: SIG4
5. The object of the declaration described above is in conformity with the relevant statutory requirements:

Supply of Machinery (Safety) Regulations 2008
Electrical Equipment (Safety) Regulations 2016
Electromagnetic Compatibility Regulations 2016
The Restriction of the Use of Certain Hazardous Substances in Electrical and Electronic Equipment Regulations 2012
Noise Emission in the Environment by Equipment for use Outdoors Regulations 2001
Measured Sound Power Level: 76dB(A), Declared Guaranteed Sound Power Level: 96dB(A)

6. References to the relevant designated standards used or references to the other technical specifications in relation to which conformity is declared:

BS EN 8528-13
BS EN 55012
BS EN 61000-6-1
BS EN ISO 3744

7. The person authorised to compile the technical file:

Name: Neil Sansom
Address: SGS Engineering (UK) Ltd, Unit 1 West Side Park, Raynesway, Derby, DE21 7AZ

Signed for and on behalf of:

Authorised Representative

A handwritten signature in blue ink, appearing to read 'Neil Sansom', written over a horizontal line.

Neil Sansom, CEO
Date: 12/06/2025

**UK
CA 25**